



POTATO PEELER PPC-6+

Output: 6 kg per cycle. Equipped with attachment drive to power accessories.



Timer (min-max): 0' - 6'
Plate speed: 317 rpm
Total loading: 550 W (1~) / 550 W (3~)

External dimensions (W x D x H)

- ✓ Width: 395 mm
- ✓ Depth: 700 mm
- ✓ Height: 447 mm

External dimensions with stand

- ✓ Width with stand: 411 mm
- ✓ Depth with stand: 700 mm
- ✓ Height with stand: 1020 mm

Net weight: 37 kg

Noise level (1m.): 70 dB(A)
Background noise: 32 dB(A)

AVAILABLE MODELS

1000430	Potato peeler PPC-6+ 230-400/50/3 · 550 W
1000431	Potato peeler PPC-6+ 230/50/1 · 550 W
1000434	Potato peeler PPC-6+ 220/60/1

* Ask for special versions availability

SALES DESCRIPTION

Aluminium made potato peeler.

Aluminium body potato peeler. Abrasive peeling. The abrasive is highly resistant and long lasting.

- ✓ Base Plate and chamber walls lined with abrasive.
- ✓ Aluminium body.
- ✓ Equipped with attachment drive to power accessories.
- ✓ Directable cylinder.
- ✓ Integral control panel complete with on/off push buttons and a 0-6 minute timer.

INCLUDES

- ✓ Attachment drive to power accessories.

OPTIONAL

- Stainless steel floor stand.
- Filter with no-foam feature.
- Vegetable preparation attachment CR-143.
- Potato masher attachment P-132.
- Meat mincer attachment HM-71.
- Water inlet kit (2003971).

ACCESSORIES

- Vegetable preparation attachment CR-143
- Meat mincer attachment HM-71
- Potato masher attachment P-132
- Stands for potato peelers PP / PPC
- Filters for potato peelers PP / PPC

SPECIFICATIONS

Hourly production: 120 kg / 150 kg
Capacity per load: 6 kg



DYNAMIC PREPARATION
COMMERCIAL POTATO PEELERS

product sheet
updated 08/04/2024



POTATO PEELER PPC-6+

Output: 6 kg per cycle. Equipped with attachment drive to power accessories.



DYNAMIC PREPARATION
COMMERCIAL POTATO PEELERS

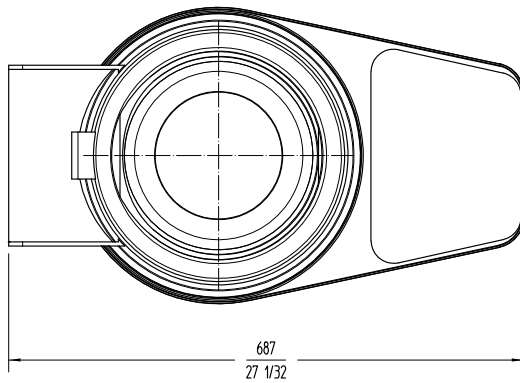
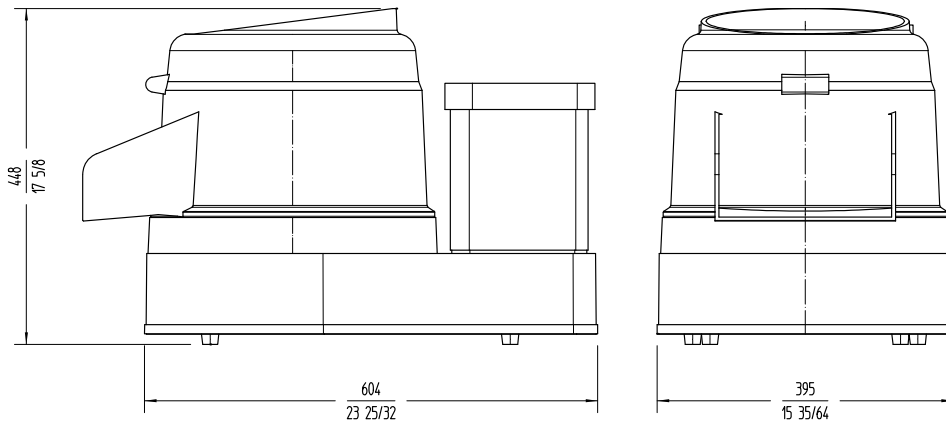

sammic | www.sammic.com
Food Service Equipment Manufacturer

Polígono Basarte, 1. phone +34 943 15 72 36
20720 Azkoitia, Spain sales@sammic.com



Project	Date
Item	Qty

Approved

product sheet
updated 08/04/2024