



# PASS-THROUGH DISHWASHER AX-100

Rack size 500 mm x 500 mm and door clearance 430 mm.



WARE WASHING  
PASS-THROUGH DISHWASHERS



## SALES DESCRIPTION

- ✓ Sani-Control: guaranteed disinfection
- ✓ Exclusive Hydroblade™ washing arms: maximum effectiveness.
- ✓ 3-stage filtering system.

### Sani-Control guarantee

- ✓ GUARANTEED DISINFECTION in compliance with standard DIN 10534.
- ✓ THERMAL LOCK function: Ensures that rinsing will be carried out at the ideal temperature to disinfect the dishes.

### New recessed bodywork

- ✓ Ergonomic design with rounded corners to prevent the accumulation of dirt and facilitate cleaning.
- ✓ Compact tank volume (50% water saving compared to the previous range).

### Hydroblade™ washing arms

- ✓ Redesigned nozzles for greater washing performance.
- ✓ The “monoblock” design delivers durability and resistance to impacts.
- ✓ 30% savings in water consumption during rinsing compared to the previous range.

### 3-stage filter system: surface, tank and extraction

- ✓ Keeps the washing water in optimal conditions to maintain constant washing performance.

### Designed to last

- ✓ “Flow” opening mechanism: allows the hood to be raised with less effort
- ✓ High load capacity 43 cm: suitable for GN 1/1 and Euronorm
- ✓ Stainless steel surface filters for greater stability and resistance during intensive use

### Warewashing, made simple

- ✓ Active Xperience: simple and intuitive use
- ✓ Dedicated cycles: selection of the ideal washing programme using icons.
- ✓ Electronic control panel with IP65 humidity protection.

### You will never WASH ALONE

- ✓ Tech-Services: our team of technicians will help you so that your machine is always ready for use.
- ✓ Design Services: tell us what your needs are and we will advise you.
- ✓ 60 years of experience and know-how at your disposal.

## INCLUDES

- ✓ Rinse aid pump.
- ✓ 1 glasses basket.
- ✓ 1 mixed basket (plates).
- ✓ 1 cutlery basket.

## OPTIONAL

- Detergent dosing kit.
- Overflow drainage pump. Tank
- water renewal by the principle of density.

## ACCESSORIES

- Tables for pass-through dishwashers
- Manual water softeners
- Automatic water softeners
- 500 x 500 mm baskets
- Inserts & supplements
- Central sorting tables
- Double connection central sorting table
- Prewashing tables for pass-through and rack conveyor dishwashers
- Connecting tables for pass-through dishwashers and rack conveyors
- Reverse osmosis devices OS-140
- Dosing equipments for AX / UX hood-type dishwashers

## SPECIFICATIONS

Basket dimensions: 500 mm x 500 mm  
Useful height: 430 mm

Cycles: 3

Cycle duration: 120 / 180 / 210"

Production baskets / hour: 30 / 24 / 17

- ✓ Boiler capacity: 8 l
- ✓ Wash tank capacity: 25 l
- ✓ Water consumption / cycle: 3 l

### Energi consumption

**Energy consumption per cycle: 0,26 kWh**

**Initial tank filling consumption: 1,07 kWh**

Loading

- ✓ Pump: 750 W / 1.0 Hp
- ✓ Tank: 2500 W
- ✓ Boiler: 6000 W
- ✓ Total loading: 6700 W

### External dimensions (W x D x H)

- ✓ Width: 650 mm (Wide with handle: 725 mm)
- ✓ Depth: 755 mm (Bottom with handle: 835 mm)
- ✓ Height: 2000 mm / 1525 mm

Wash temperature: 65°C  
Rinse temperature: 85°C  
Net weight: 102 kg  
Noise level (1m.): <70 dB(A)



product sheet  
updated 12/04/2024



# PASS-THROUGH DISHWASHER AX-100

Rack size 500 mm x 500 mm and door clearance 430 mm.



WARE WASHING  
PASS-THROUGH DISHWASHERS

### Crated dimensions

760 x 860 x 1530 mm

Gross weight: 113 kg

### AVAILABLE MODELS

1303300 AX-100 400/50/3N

1303303 AX-100 220/60/3

1303309 AX-100 220/60/1

1303305 AX-100B 400/50/3N

1303308 AX-100B 220/60/3

1302388 AX-100 220/60/1 M

\* Ask for special versions availability

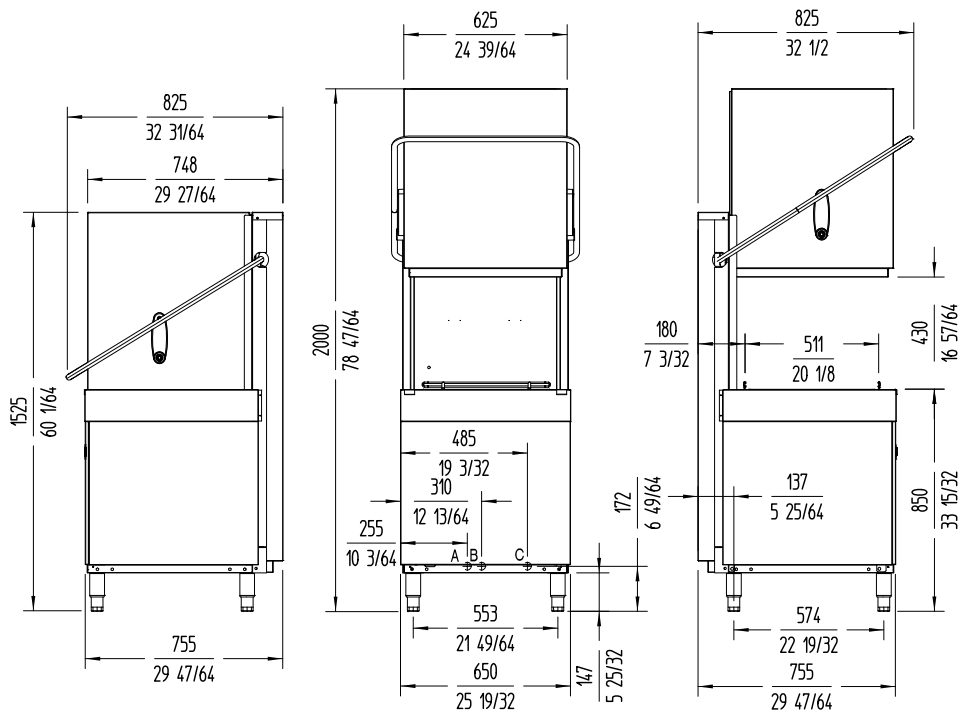

A: Entrada de agua 3/4" GAS.  
 B: Tubo de desague Ø30 mm.  
 C: Cable conexión.

**sammic** | www.sammic.com  
 Food Service Equipment Manufacturer

Polígono Basarte, 1. phone +34 943 15 72 36  
 20720 Azkoitia, Spain sales@sammic.com



Project	Date
Item	Qty
Approved	

product sheet  
 updated 12/04/2024