



# TURBO LIQUIDISER TRX-21

1-speed turbo-mixer



DYNAMIC PREPARATION  
TURBO LIQUIDISERS



## SALES DESCRIPTION

Turbo-blender designed to work in up to 800 litre / 130 gal. bowls.

## FEATURES AND BENEFITS

- ✓ Fully manufactured in stainless steel 18/10.
- ✓ For mixing and liquidising directly in the pot or pan for making consommés, soups, omelettes, mayonnaise, etc.
- ✓ Designed for large yields and for frequent use and cleaning, ideal for kitchens with a large production and the food industry.
- ✓ 1-speed model.
- ✓ Ease of use: can be moved in several directions, adjustable height, fitted on a trolley with 4 non-slip rubber wheels, 2 of them with brakes.
- ✓ Arm: 600 mm long for blending in any type of cooking pot, whether round or rectangular, equally effective throughout the whole pot.
- ✓ Balanced liquidiser arm: stops the arm falling or tipping back when not locked.
- ✓ Arm securing lever: allows you to lock the blender with one hand while holding the trolley with the other.
- ✓ Watertight, tilted control panel: easy access even during use.
- ✓ Control panel located on the trolley, making the arm more agile, with better mobility.
- ✓ Control panel with built-in timer: you can leave the machine running for up to 60 minutes without the need for user involvement.
- ✓ Wiring incorporated into the trolley tubes: The work area is free of cables, so as not to hinder the movement of the blender arm.
- ✓ Supports for storing the power supply cable: prevents the cable getting tangled and inconveniencing other users.
- ✓ The turbine, disc and grille are very easy to remove for cleaning: no tools needed.
- ✓ The turbine, guard, disc and attachment can be cleaned in dishwashers.
- ✓ For use with 3 easily interchangeable attachments, which meet the needs of all users and ingredients.
- ✓ 21D for fibrous ingredients
- ✓ Standard 30D multi-use attachment
- ✓ 42D attachment for very fine blending
- ✓
- ✓ Safety microswitch to control the work position: prevents the turbine working if the arm is too high or low.
- ✓ Safety guard on the liquidiser head and safety device that cuts out the power supply.

## INCLUDES

- ✓ Trolley, motor and arm (without attachments).

## ACCESSORIES

- Grids for TRX



**sammic** | [www.sammic.com](http://www.sammic.com)  
Food Service Equipment Manufacturer

Polígono Basarte, 1. phone +34 943 15 72 36  
20720 Azkoitia, Spain [sales@sammic.com](mailto:sales@sammic.com)



Project	Date
Item	Qty
Approved	

product sheet  
updated 22/03/2019



# TURBO LIQUIDISER TRX-21

1-speed turbo-mixer



## SPECIFICATIONS

Maximum recipient capacity: 800 l

Liquidising arm length: 600 mm

Total loading: 2200 W

Speed (in liquid): 1500 rpm

### External dimensions (WxDxH)

✓ Width: 568 mm

✓ Depth: 1643 mm (963 mm)

✓ Height: 1219 mm (1651 mm)

Net weight: 96 Kg

Noise level (1m.): <70 dB(A)

Background noise: 32 dB(A)

### Crated dimensions

1030 x 710 x 1840 mm

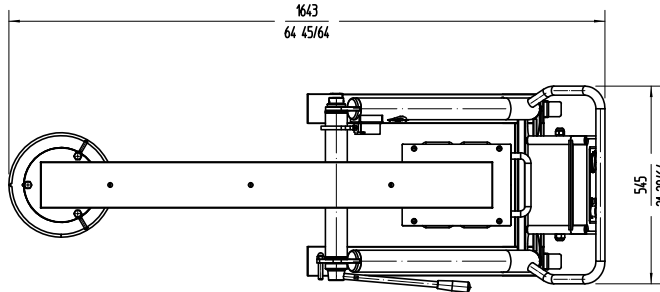
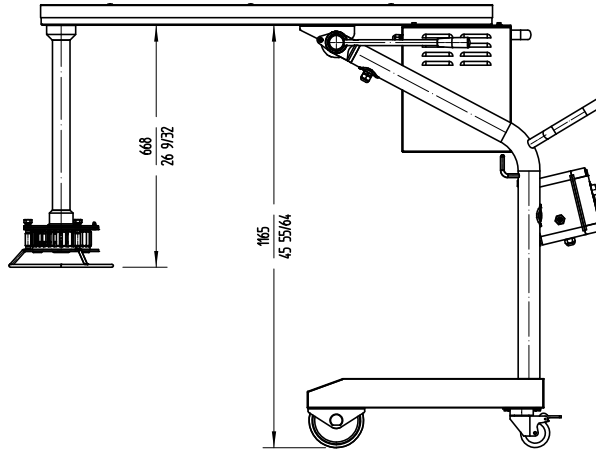

DYNAMIC PREPARATION  
TURBO LIQUIDISERS

## AVAILABLE MODELS

3030501 Turbo liquidiser TRX-21 230-400/50/3N

9500120 TRX-21 1.500rpm - 230-400V / 50 Hz / 3N (with one grid)

\* Ask for special versions availability

**sammic** | [www.sammic.com](http://www.sammic.com)  
Food Service Equipment Manufacturer

Polígono Basarte, 1. phone +34 943 15 72 36  
20720 Azkoitia, Spain [sales@sammic.com](mailto:sales@sammic.com)



Project

Date

Item

Qty

Approved

product sheet  
updated 22/03/2019